

Operating and installation instructions

Open barbecue grill

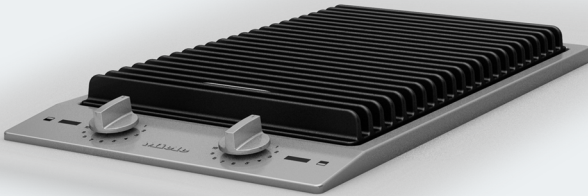

To avoid the risk of accidents or damage to the appliance, it is **essential** to read these instructions before it is installed and used for the first time.

Contents

Guide to the appliance	4
CS 1312	4
CS 1322	5
Warning and Safety instructions	7
Caring for the environment	12
Before using for the first time	13
Operation	14
Grill chart	14
To prepare the grill	16
Switching on and off	16
Grilling	17
Useful tips	17
After grilling	17
Safety features	18
Overheating protection	18
Safety cut-out	18
Cleaning and care	19
Problem solving guide	22
Optional accessories	23
Safety instructions for installation	25
Safety clearance	26
Appliance and building-in dimensions	28
CS 1312	28
CS 1322	29
Preparing the worktop	30

Contents

Installation of several appliances	31
Fixing the spring clamps and spacer bars	34
Installing/removing the appliance(s)	36
General installation tips	37
Electrical connection	38
After sales service, data plate, warranty	39

Guide to the appliance

CS 1312

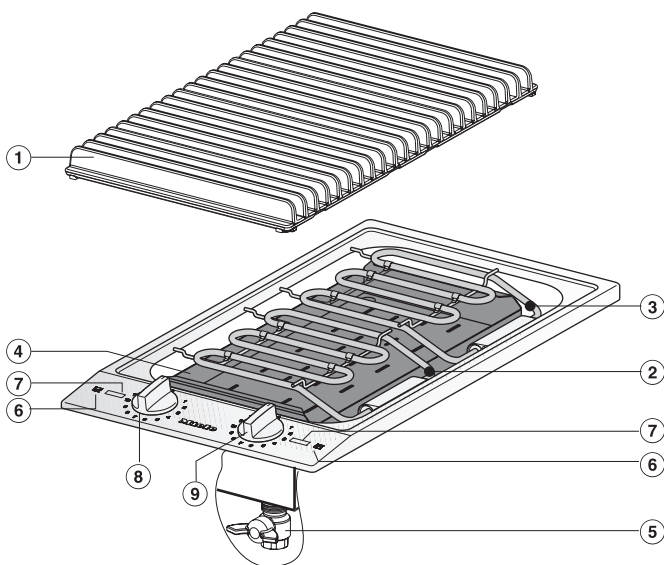

- ① Grill rack
- ② Front heating element
- ③ Rear heating element
- ④ Lava rock container
- ⑤ Drain tap
- ⑥ Symbols to indicate which heating element the control is for
- ⑦ Display

Controls for the heating elements:

- ⑧ Front
- ⑨ Rear

Display



- ⑩ In-operation indicator

CS 1322

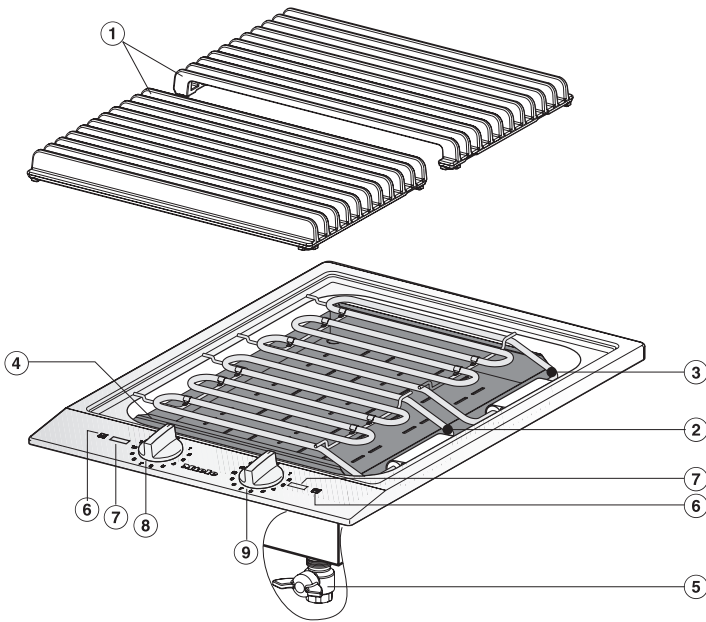

- ① Grill rack
- ② Front heating element
- ③ Rear heating element
- ④ Lava rock container
- ⑤ Drain tap
- ⑥ Symbols to indicate which heating element the control is for
- ⑦ Display

Controls for the heating elements:

- ⑧ Front
- ⑨ Rear

Display



- ⑩ In-operation indicator

Guide to the appliance

Accessories supplied

Additional accessories can be ordered at extra cost. See "Optional accessories" for further details on ordering.

Lava rocks

Tongs

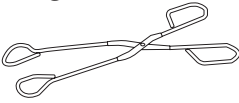

Brush



Warning and Safety instructions

This appliance complies with all relevant local and national safety requirements. Inappropriate use can, however, lead to personal injury and damage to property.

To avoid the risk of accidents and damage to the appliance, please read these instructions carefully before using it for the first time. They contain important notes on installation, safety, use and maintenance.

Keep these instructions in a safe place and ensure that new users are familiar with the content. Pass them on to any future owner.

Correct application

- ▶ This grill is designed for domestic use and for use in similar environments by guests in hotel or motel rooms, bed & breakfasts and other typical living quarters. This does not include common/shared facilities or commercial facilities within hotels, motels or bed & breakfasts.
- ▶ This appliance must only be used as described in these instructions. Any other usage is at the owner's risk and could be dangerous. Miele cannot be held liable for damage resulting from incorrect or improper use or operation.
- ▶ This appliance is not intended for use by persons (including children) with reduced physical, sensory or mental capabilities, or lack of experience or knowledge, unless they have been given supervision or instruction concerning its use by a person responsible for their safety.
- ▶ This appliance is not suitable for outdoor use.
- ▶ This appliance must not be installed and used in mobile installations such as ships etc.
- ▶ Do not modify this appliance.

Warning and Safety instructions

Safety with children

▶ Children should be supervised to ensure that they do not play with the appliance.

▶ Older children may only use the grill when its operation has been clearly explained to them and they are able to use it safely, recognising the dangers of misuse.

▶ The grill gets hot when in use and remains hot for quite a while after being switched off. To safeguard against burning, keep children well away from the appliance at all times.

▶ Do not store anything which might arouse a child's interest in storage areas above or next to the appliance. Otherwise they could be tempted into climbing onto the appliance with the risk of burning themselves.

▶ Ensure that children cannot reach the drain tap where hot liquid could be drained out.

▶ Packaging, e.g. cling film, polystyrene and plastic wrappings, must be kept out of the reach of babies and young children. Danger of suffocation. Dispose of or recycle all packaging safely as soon as possible.

Warning and Safety instructions

Technical safety

► Before installation, check the appliance for visible signs of damage. Do not install and use a damaged appliance. A damaged appliance is dangerous.

► The electrical safety of this appliance can only be guaranteed when continuity is complete between it and an effective earthing system which complies with local and national safety regulations. It is most important that this basic safety requirement is present and regularly tested and, where there is any doubt, the household wiring system should be inspected by a qualified electrician. The manufacturer cannot be held liable for the consequences of an inadequate earthing system (e.g. electric shock).

► Before connecting the appliance, make sure that the connection data on the data plate (voltage and rated load) match the mains electricity supply. This data must correspond in order to avoid the risk of damage to the appliance. Consult a qualified electrician if in any doubt.

► For safety reasons, this appliance may only be used after it has been built in.

► Never open the housing of the appliance. Tampering with electrical connections or components and mechanical parts is highly dangerous to the user and can cause operational faults.

► Installation, maintenance and repairs may only be carried out by a suitably qualified and competent person in strict accordance with current national and local safety regulations. Repairs and other work by unqualified persons could be dangerous. Miele cannot be held liable for unauthorised work.

► During installation, maintenance and repair work, the appliance must be disconnected from the mains electricity supply. It is only completely isolated from the electricity supply when:

- the mains fuse is disconnected,
- the screw-out fuse is removed (in countries where this is applicable),
- it is switched off at the wall socket and the plug is withdrawn from the socket, or
- it is switched off at the isolator.

► While the appliance is under warranty, repairs should only be undertaken by a service technician authorised by Miele. Otherwise the warranty will be invalidated.

► Faulty components must only be replaced by genuine Miele original spare parts. The manufacturer can only guarantee the safety of the appliance when Miele replacement parts are used.

Warning and Safety instructions

▶ If the connection cable is damaged, it must be replaced by a suitably qualified electrician with a specialist connection cable of type H 05 VV-F (pvc insulated), available from Miele.

▶ Do not connect the appliance to the mains electricity supply by a multi-socket unit or an extension lead. These do not guarantee the required safety of the appliance (e.g. danger of overheating).

▶ This appliance is not intended to be operated by means of an external timer or separate remote control system.

▶ This appliance may be connected via a fused plug and switched socket. If you wish to connect it to an isolator switch, or if the appliance is supplied without a plug, it must be installed and connected by a suitably qualified and competent person in strict accordance with current local and national safety regulations. The manufacturer cannot be held liable for damage caused by incorrect installation or connection.

▶ In areas which may be subject to infestation by cockroaches or other vermin, pay particular attention to keeping the appliance and its surroundings in a clean condition at all times. Any damage caused by cockroaches or other vermin will not be covered by the warranty.

Correct use

▶ The grill gets hot when in use and remains hot for quite a while after being switched off.

Caution: Danger of burning.

▶ Do not leave the appliance unattended whilst it is being used. Overheated fat, oil or food residues in the lava rocks could ignite and cause a fire.

▶ If oil or fat does catch fire, do not attempt to put out the flames with water. Use a suitable fire blanket, saucepan lid, damp towel or similar to smother the flames.

▶ Do not use the appliance to heat up the room, and never switch it on with the heating element in the raised position. Due to the high temperatures radiated, objects near the appliance could catch fire. The life of the appliance could also be reduced.

▶ For added protection, it is advisable to use heat-resistant pot holders or gloves when using the appliance. Do not let them get damp or wet, as this causes heat to transfer through the material more quickly with the risk of scalding or burning yourself.

▶ Do not flambé under a rangehood. The flames could set the rangehood on fire.

Warning and Safety instructions

▶ Do not use the appliance as a resting place for anything else. When the appliance is switched on either deliberately or by mistake, or when there is residual heat present, there is the risk of metal objects heating up, with a danger of burning. Depending on the material, objects left on the appliance could melt or catch fire.

Switch the appliance off after use.

▶ Installing several appliances

Do not place any hot pots or pans near the spacer bar as they could damage the sealing strip of the spacer bar.

▶ Do not cover the appliance, e.g. with a covering plate, a cloth, kitchen foil etc. If the appliance is switched on by mistake, or if there is residual heat, these materials may catch fire, shatter or melt.

▶ When grilling or keeping food warm, do not use grill pans, griddles, saucepans or similar on the open grill, and never cover the rack (e.g. with aluminium foil) or use disposable aluminium foil containers. The resulting build-up of heat could damage the rack(s).

▶ Do not heat up unopened tins of food on the appliance as pressure will build up in the tin, causing it to explode. This could result in injury and scalding or damage.

▶ Clean the lava rocks regularly and replace them when necessary. Rocks which are saturated with fat catch fire easily.

▶ The grill trough must always be filled with water whenever the grill is in use.

▶ When using an electrical appliance, e.g. a hand-held mixer, near the grill, ensure that the connection cable doesn't come into contact with the grill. The insulation on the cable could become damaged, giving rise to an electric shock hazard.

▶ If the grill is built-in behind a furniture door, it must only be operated when the door is open.

Close the furniture door only once the appliance has completely dried out.

Miele cannot be held liable for damage caused by non-compliance with these Warning and Safety instructions.

Caring for the environment

Disposal of the packing material

The transport and protective packing has been selected from materials which are environmentally friendly for disposal and can normally be recycled.

Ensure that any plastic wrappings, bags, etc. are disposed of safely and kept out of the reach of babies and young children. Danger of suffocation.

Rather than just throwing these materials away, please ensure they are offered for recycling.

Disposal of your old appliance or machine

Electrical and electronic appliances / machines often contain materials which, if handled or disposed of incorrectly, could be potentially hazardous to human health and to the environment. They are, however, essential for the correct functioning of your appliance or machine. Therefore, please do not dispose of your old machine or appliance with your household waste.

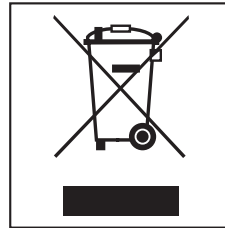

Please dispose of it at your local community waste collection / recycling centre and ensure that it presents no danger to children while being stored for disposal.

It should be unplugged or disconnected from the mains electricity supply by a competent person. The plug must be rendered useless and the cable cut off directly behind the appliance or the machine to prevent misuse.

Before using for the first time

Please stick the extra data plate for the appliance supplied with this documentation in the space provided in the "After sales service" section of this booklet.

Cleaning for the first time

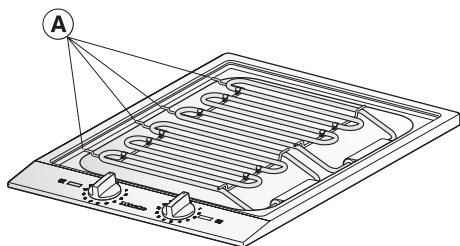

The metal components have a protective coating which may give off a slight smell when heated up for the first time.

The smell and any vapours will dissipate after a short time, and do not indicate a faulty connection or appliance.

- Remove the protective sleeves **A** from the heating elements and any protective foil from the appliance.
- Wash the grill trough and the rack in hot water with a little washing-up liquid, and dry thoroughly (see "Cleaning and care").
- Clean the other surfaces with a damp cloth, and then wipe dry.

Operation

Grill chart

The times given in the table serve as a guide, based on a pre-heated grill at settings 9 to 12. The grilling time required will depend on the type of food, its texture and thickness as well as personal taste.

Food	Time in minutes
Meat and sausages	
Sausages	6 - 8
Fillet steak	4 - 10
Burgers	12 - 16
Chicken drumsticks	16 - 18
Lamb chops	4 - 8
Liver	3 - 6
Turkey escalopes	8 - 10
Kebabs	14 - 18
Cutlets/schnitzel	8 - 12
Spare ribs	15 - 20
T-bone steak	10 - 20
Fish and seafood	
Trout	12 - 16
Prawns	2 - 4
Salmon steak	10 - 12
Mackerel	10 - 12
Tuna fish steak	6 - 8

Food	Time in minutes
Vegetables	
Eggplants	6 - 8
Jacket potatoes, pre-cooked	10 - 20
Vegetarian kebabs	5 - 6
Corn on the cob, pre-cooked	5 - 8
Capsicum, cut into strips	2 - 3
Tomato halves	2 - 4
Fruit	
Pineapple slices	2 - 3
Apple slices	2 - 3
Miscellaneous	
Toast	2 - 3
Tofu	4 - 6

Operation

To prepare the grill

The grill can be used with or without the lava rocks, but always with water in the trough. Without the lava rocks the rising steam keeps the food being grilled moist. Grilling with the lava rocks creates a particularly intensive aroma.

- Check that the drain tap is closed.
- Remove the rack (or racks, depending on model), lift up the heating elements, and if not being used, take the lava rock container out.
- Fill the grill trough

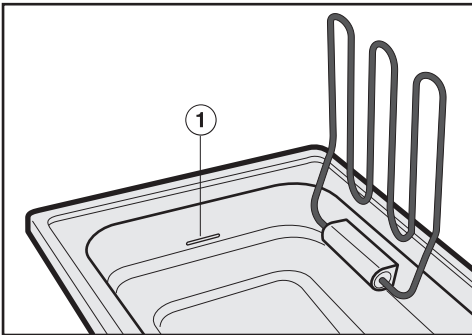

- when grilling **without lava rocks** up to marker line ① with approx. 2.5 litres of water (CS 1312) approx. 4.0 litres of water (CS 1322).
- when grilling **with lava rocks** with approx. 1.2 litres of water (CS 1312) approx. 1.8 litres of water (CS 1322).
- If using lava rocks, put the container back in the grill trough.
- Lower the heating elements again, and put the rack back on it.

Switching on and off

The grill has 2 heating elements which can be switched on and regulated independently. Both elements can be used together when grilling large quantities of food. For smaller quantities, the front element can be used to grill the food whilst the rear element can be used to keep food warm at settings 3 or 4.

To switch the heating elements on or off, the appropriate control is turned in a clockwise or anti-clockwise direction.

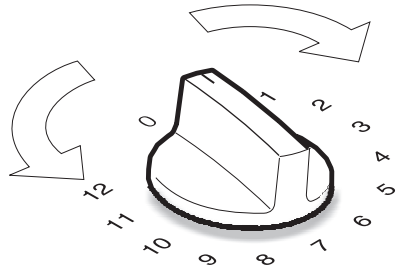

- Lights up in the display after the appliance has been switched on, and goes out again once the grill has been switched off.

Grilling

When grilling, keep an eye on the level of water in the trough. If necessary, add more water.

When grilling or keeping food warm, do not use grill pans, griddles, saucepans or similar on the open grill, and never cover the rack(s) (e.g. with aluminium foil). The resulting build-up of heat could damage the rack(s).

 Do not leave the appliance unattended whilst it is being used.

- Turn one or both controls to setting "12".
- Pre-heat the grill with the rack(s) in place for approx. 10 minutes.

Make sure the control(s) are set precisely to setting 12. If the controls are not set to the exact position, the heating will not work with maximum power.

- Select the setting you require.
- Turn the food once or more during grilling.

Useful tips

- Pat dry wet food with kitchen paper to absorb surplus moisture and avoid spitting.
- To prevent meat drying out, do not season with salt until after it has been cooked.
- Marinating often improves the flavour of food to be grilled.
- Brush food that has not been marinated with a little oil. Only use oils that can be heated to a high temperature.
- The grilling time for jacket potatoes and corn on the cob can be reduced by pre-cooking potatoes for 15-40 minutes (depending on the size) and corn on the cob for 10-15 minutes.

After grilling

- Switch off the appliance.
- Clean the grill after each use while it is still warm to the touch (see "Cleaning and care").
- After grilling check the appearance of the lava rocks. If they look dark, they are saturated with oil and must be cleaned or replaced.

Safety features

Overheating protection

A safety cut-out automatically switches the appliance off if the water level drops too low.

- Add some cold water.

As soon as the appliance has cooled down, the heating elements switch back on again and you can continue grilling.

Safety cut-out

A safety cut-out ensures that the grill elements only heat up when they are lying horizontally and not when they are raised up.

 Under no circumstances use a steam cleaning appliance to clean this appliance. The steam could attack the electrical components and cause a short circuit. Pressurised steam could also cause permanent damage to the surface and to other components, for which the manufacturer cannot accept liability.

Clean the appliance regularly, preferably after each use. Allow the appliance to cool down to a safe temperature before cleaning. After cleaning, the grill must be thoroughly dried with a soft cloth to prevent a build-up of limescale deposits.

Abrasive cleaning agents and scouring sponges may only be used to clean the heating elements.

To avoid damaging the stainless steel surfaces of your appliance, do not use:

- cleaning agents containing soda, alkalines, ammonia, acids or chlorides,
- cleaning agents containing descaling agents,
- stain or rust removers,
- abrasive cleaning agents, e.g. powder cleaners and cream cleaners,
- solvent-based cleaning agents,
- dishwasher cleaner,
- grill and oven cleaners,
- glass cleaning agents,
- hard, abrasive brushes or sponges, e.g. pot scourers, brushes or sponges which have been previously used with abrasive cleaning agents,
- sharp pointed objects (these can damage the seal between the frame and the worktop).

Cleaning and care

Stainless steel

The Original Miele ceramic and stainless steel cooktop cleaner is suitable for cleaning stainless steel surfaces (see "Optional accessories"). To help prevent resoiling, we recommend a stainless steel conditioner (see "Accessories"). Apply sparingly with a soft cloth.

Do not use stainless steel cleaning agents on **printed** surfaces. This would rub off the print. These areas should only be cleaned with an E-Cloth or with a solution of warm water and a small amount of washing-up liquid applied with a soft sponge.

Racks and lava rock container

Wash the racks and lava rock container after every use in hot water and a small amount of washing-up liquid. Soak to remove heavy soiling, and then scrub clean with a brush. Leave them to dry thoroughly.

Do not use cleaning agents for stainless steel on the lava rock container.

Heating elements

Use a scouring sponge to clean any residues left on the heating elements.

Lava rocks

To prevent smells, clean the lava rocks regularly.

Soak them in a suitable container in hot water with a small amount of washing-up liquid, then swirl them around in the water several times. Pour away the dirty water, and rinse 2 or 3 times in clean water. Lay the rocks out to dry on a suitable towel.

Whenever the lava rocks are washed, the used surface is worn away. How quickly the lava rocks wear down depends on how often they are used and for how long.

If the lava rocks in the lava rock container are reduced by half, they need to be replenished.

Grill trough

- After grilling, allow the water in the trough to cool down before draining it.
- Place a container large enough to take the contents of the trough under the drain.
- Open the drain tap under the grill by turning it **anti-clockwise** ①.

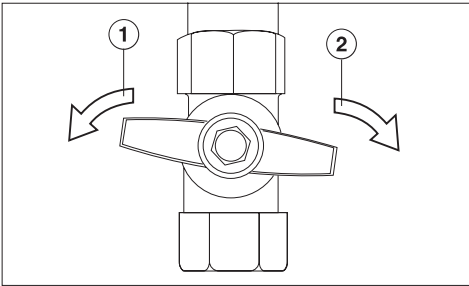

- Once the water has all drained, turn off the tap by turning it **clockwise** ② as far as it will go.
- Fill the grill trough with hot water and a small amount of washing-up liquid, clean it thoroughly.
- Drain the dirty water, and clean the drain with a bottle brush. Rinse with hot water, and then wipe the grill trough and the drain dry.

Never use a conditioning agent for stainless steel on the grill trough.

Ensure that the underside of the grill is always easily accessible for draining water. Always wait until the water has cooled down before draining to avoid the danger of being scalded.

Do not connect the drain valve directly to any onsite drainage outlets. Trough contents must be drained into a container.

Problem solving guide

Installation work and repairs to electrical appliances must only be carried out by a suitably qualified and competent person in strict accordance with current local and national safety regulations. Repairs and other work by unqualified persons could be dangerous. The manufacturer cannot be held liable for unauthorised work.

What to do if...

... after switching on, the appliance does not heat up.

Check whether

- the overheating protection mechanism has been activated. Proceed as described in "Overheating protection".
- the mains fuse has tripped. If it has, contact a qualified electrician or Miele.

... the food does not begin to brown when the appliance has been pre-heated at setting "12" for 10 minutes.

- Check that the control marker is exactly at setting "12". If it is between settings "12" and "0", the grill heats at a lower power setting.

Optional accessories

Miele offers a range of useful accessories, as well as cleaning and conditioning products for your appliance.

Depending on country, these can be ordered online at:



These products can also be obtained by contacting Miele (see back of instructions for contact details).

Griddle CSGP 1300

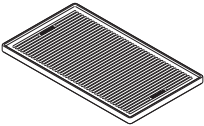

Cast-iron griddle to place on top of the CS 1312 grill, with a flat and a fluted side

Wire frame for griddle CSPG 1300

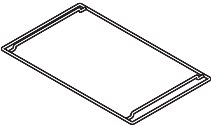

Handle

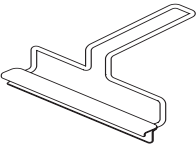

Cleaning and conditioning products

Original Miele ceramic and stainless steel cooktop cleaner 250 ml



Removes heavy soiling, limescale deposits and light discolouration.

Optional accessories

Original Miele stainless steel conditioning agent 250 ml



Removes water marks, flecks and finger prints.
Helps keep the appliance looking good for longer.

Original Miele all-purpose microfibre cloth

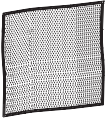

Removes finger marks and light soiling.

Safety instructions for installation

Fit the wall units and rangehood before fitting the barbecue grill to avoid damaging the surface.

- ▶ The veneer or laminate coatings of worktops (or adjacent kitchen units) must be treated with 100 °C heat-resistant adhesive which will not dissolve or distort. Any backmoulds must be of heat-resistant material.
- ▶ After installing the grill, ensure that the connection cable is without hindrance and that there is no mechanical obstruction which could damage it, e.g. when draining the appliance.
- ▶ This appliance must not be installed and operated in mobile installations (e.g. on a ship).
- ▶ Ensure that the electrical cable is installed in such a way that it does not touch any parts of the appliance which become hot. The cable will be damaged by extreme heat.
- ▶ Observe carefully the safety distances given on the following pages.

All dimensions in this instruction booklet are given in mm.

 This appliance must be installed and connected to services in accordance with local and national safety and building regulations.

Safety clearance

Safety clearance above the grill

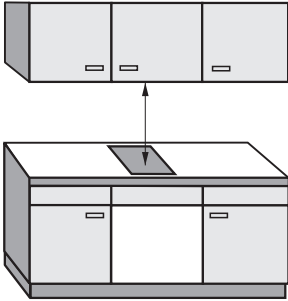

When two or more appliances are installed together below a rangehood, e.g. a grill and an induction cooktop combiset, which have different safety clearances given in the installation instructions, you should select the greater distance of the two.

A minimum safety clearance of 650 mm must be maintained between the appliance and the rangehood above it unless a greater distance is specified by the manufacturer of the rangehood.

If the manufacturer's instructions are not available for the rangehood, then a minimum safety clearance of at least 760 mm must be maintained. For any flammable objects, e.g. utensil rails, wall units etc., a minimum safety clearance of at least 760 mm must be maintained between them and the appliance below.

Side / rear clearances to the cooktop

Ideally the cooktop should be installed with plenty of space on either side. There may be a wall at the rear and a tall unit or wall at one side. On the other side, however, no unit or divider should stand higher than the cooktop (see illustrations).

Before installing the appliance, check that the below clearance requirements are met.

- ① The horizontal distance from the **back edge** of the cooktop to a vertical surface shall be 50 mm minimum.
- ② The horizontal distance from the **right edge** of the cooktop to a vertical surface shall be 150 mm minimum.
- ③ The horizontal distance from the **left edge** of the cooktop to a vertical surface shall be 150 mm minimum.

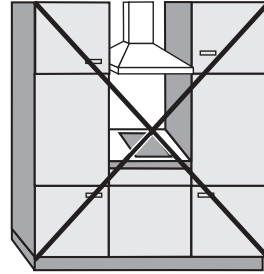

Not allowed

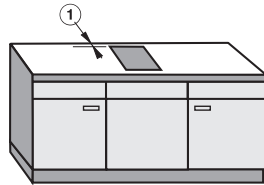
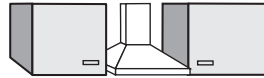

Recommended

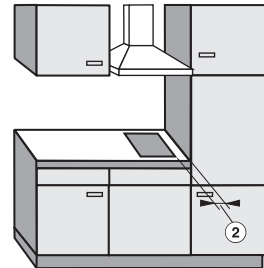

Not recommended

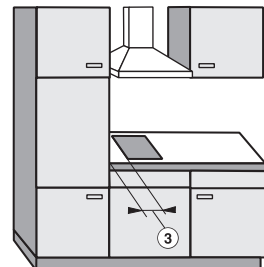

Not recommended

Appliance and building-in dimensions

CS 1312

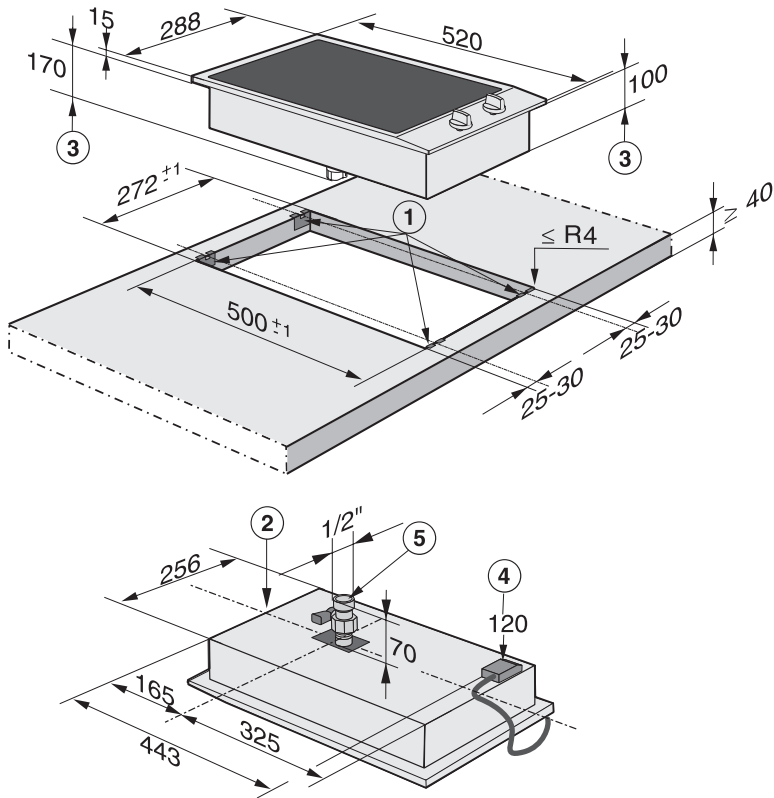

- ① Spring clamps
- ② Front
- ③ Building-in depth
- ④ Installation height of mains connection box with mains connection cable,
L = 2,000 mm
- ⑤ Drain tap

Appliance and building-in dimensions

CS 1322

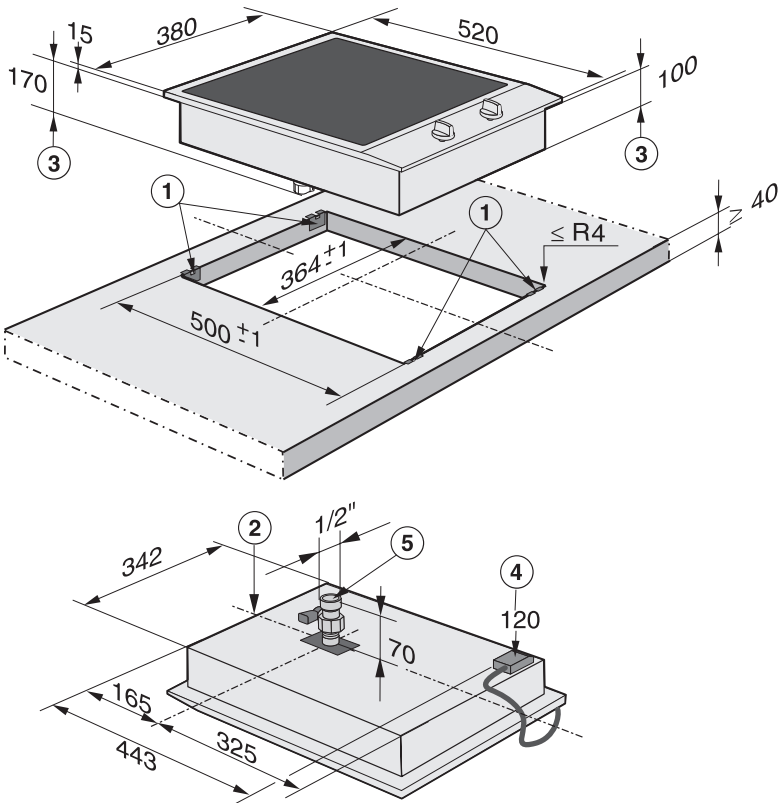

- ① Spring clamps
- ② Front
- ③ Building-in depth
- ④ Installation height of mains connection box with mains connection cable,
L = 2,000 mm
- ⑤ Drain tap

Preparing the worktop

- Make the worktop cut-out for one or more appliances as applicable. Remember to maintain a **minimum safety clearance** from the **back wall**, as well as from any **tall unit or side wall** to the right or left of the appliance(s). See "Safety clearances".
- Seal the cut surfaces with a suitable heat-resistant sealant to avoid swelling caused by moisture.

If, during installation, you find that the seals on the corners of the frame are not flush with the worktop surface, the corner radius ($\leq R4$) can be carefully scribed to fit.

Installation of several appliances

When installing two or more appliances next to each other, a spacer bar ② must be used between each one.

See "Fitting the spacer bars and support brackets".

Worktop cut-out - two appliances

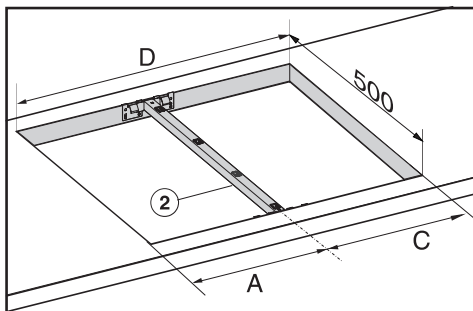

When installing **two appliances**, the width of the cut-out required (D) is calculated by adding dimensions (A) and (C).

A = appliance width (288 mm or 380 mm or 576 mm) **less 8 mm**

B = appliance width (288 mm or 380 mm or 576 mm)

C = appliance width (288 mm or 380 mm or 576 mm) **less 8 mm**

D = width of worktop cut-out

Worktop cut-out - three appliances

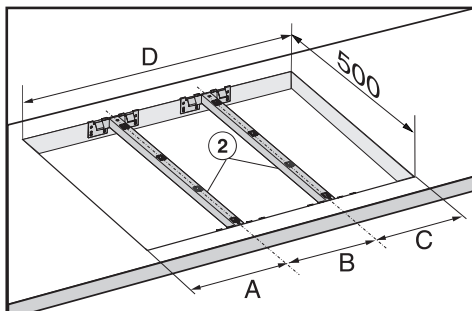

When installing **three appliances**, the width of the cut-out required (D) is calculated by adding dimensions (A), (B) and (C).

When installing **more than three appliances**, for each additional appliance, add the relevant appliance width (288 mm or 380 mm or 576 mm) to dimensions A, B and C.

Installation of several appliances

Worktop cut-out calculation example for three appliances

A Appliance width less 8	B Appliance width	C Appliance width less 8	D Worktop cut-out
280	288	280	848
280	380	372	1032
280	576	568	1424
372	288	280	940
372	380	372	1124
372	576	568	1516
568	288	280	1136
568	380	372	1320
568	-	568	1136

All dimensions are given in mm

Installation of several appliances

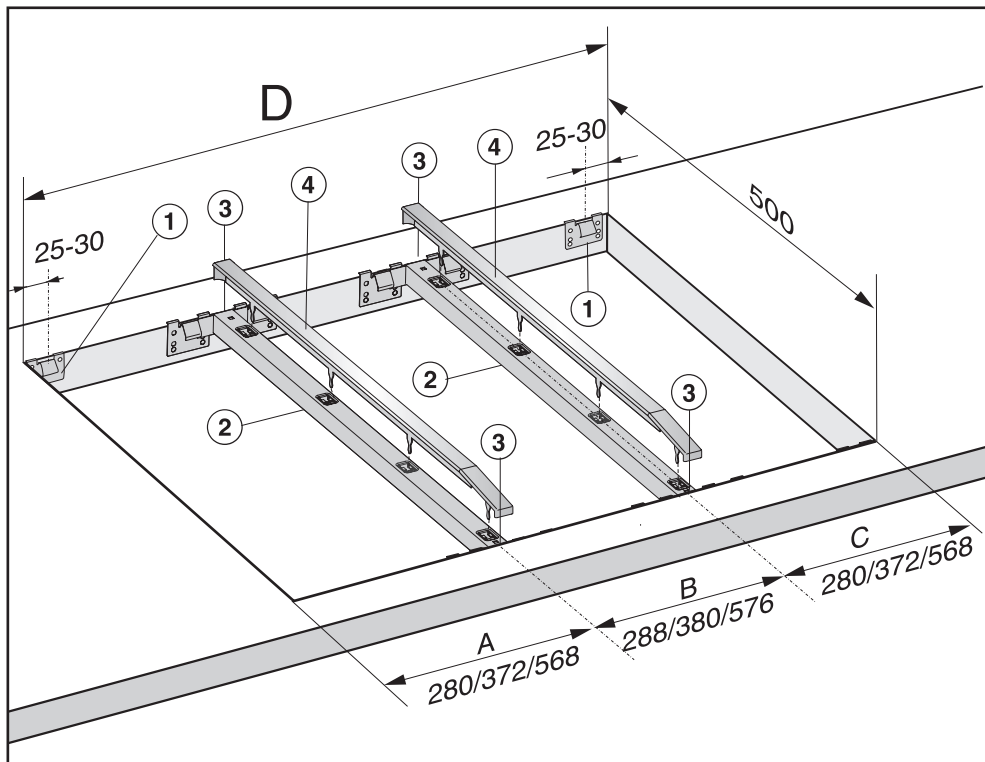

- ① Spring clamps
- ② Spacer bars
- ③ Gap between spacer bar and worktop
- ④ Cover

The illustration shows a worktop cut-out with spring clamps ① and spacer bars ② for 3 appliances.

An additional spacer bar is required for each additional appliance. The position for securing each additional spacer bar will depend on the width of appliance **B** (288 mm / 380 mm / 576 mm).

Fixing the spring clamps and spacer bars

Wooden worktops

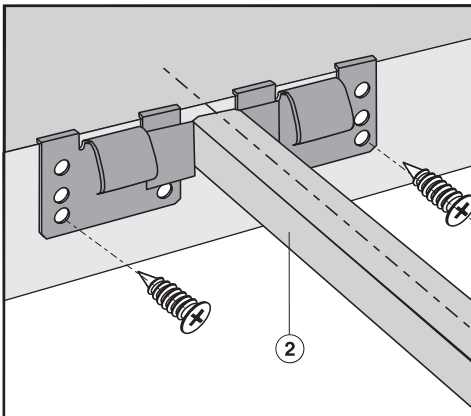
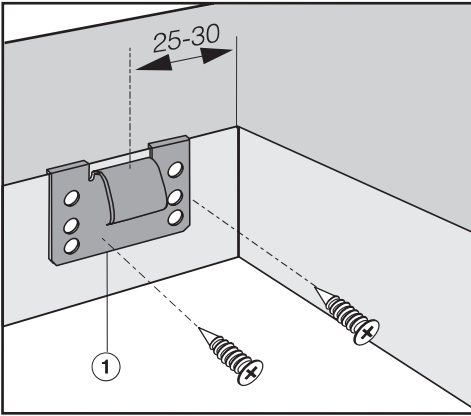

- Position the spring clamps supplied ① and spacer bars ② on the top edge of the cut-out in the positions marked.
- Secure the spring clamps and spacer bars with the 3.5 x 25 mm screws supplied.

Fixing the spring clamps and spacer bars

Granite and marble worktops

The screws are not required for granite or marble worktops.

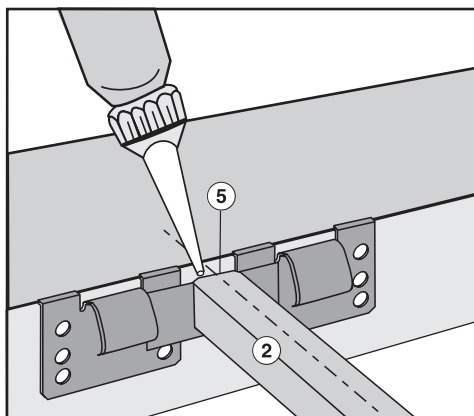
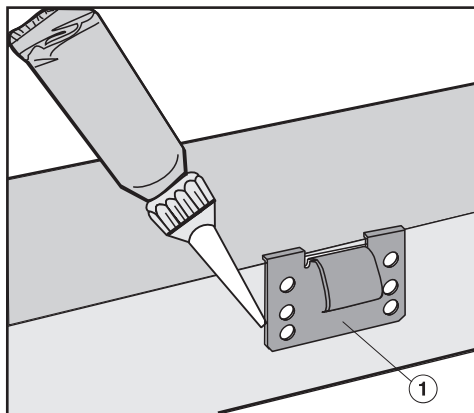
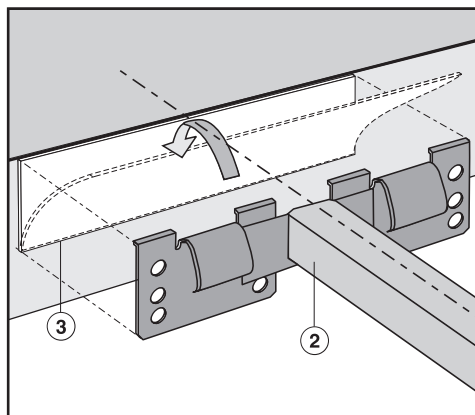
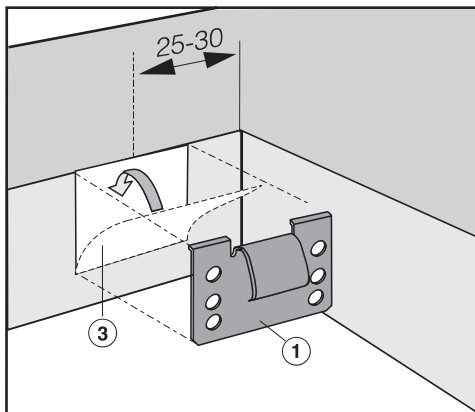

- Position and secure the spring clamps ① and spacer bars ② using strong, double-sided adhesive tape ③.

- Coat the side edges and the lower edges of the spring clamps ① and the spacer bars ② with silicone.
- Then fill gap ⑤ between the spacer bars and the worktop with silicone.

Installing/removing the appliance(s)

Installing the appliance

- Feed the connection cable down through the cut-out.
- Place the appliance into the worktop cut-out, starting with the front of the appliance.
- Using both hands, press down evenly on the sides of the appliance until it clicks into position. When doing this, make sure that the seal sits flush with the worktop on all sides. This is important to ensure an effective seal all round. **Do not use sealant.**

When installing several appliances, a cover must be inserted into the spacer bar.

- Slide the installed appliance to one side until you can see the holes of the spacer bar.

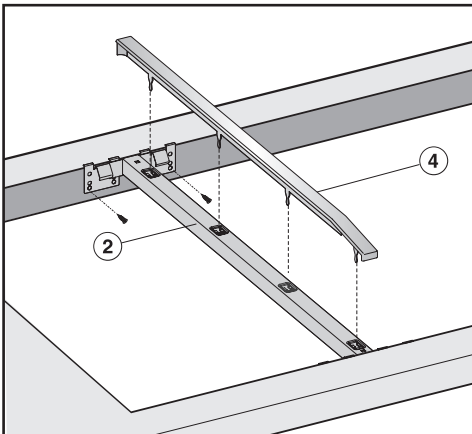

- Insert the cover ④ into the holes of the spacer bar ②.

- Place the appliance into the worktop cut-out, starting with the front of the appliance.
- Connect the appliance to the mains electricity (see "Electrical connection").
- Check that the appliance works.

Removing the appliance

If the appliance is accessible from below, push it out from underneath, starting at the back.

In stubborn cases, or if the appliance is not accessible from below, use a cooktop lever (available from Miele) to lift up the cooktop. To prevent damage to the worktop, position a cloth or similar under the cooktop lever. Warning: Do not use a screwdriver to lift up the cooktop as this will damage the appliance.

Seal between the appliance and the worktop

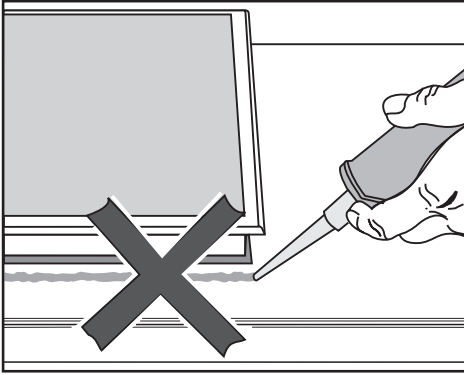

The sealing strip under the edge of the top part of the appliance provides a sufficient seal for the worktop.

Do not use any additional sealant (e.g. silicone) between the appliance and the worktop. This could cause difficulties if the appliance ever needs to be taken out for servicing and possibly result in damage to the appliance or the worktop.

Tiled worktop

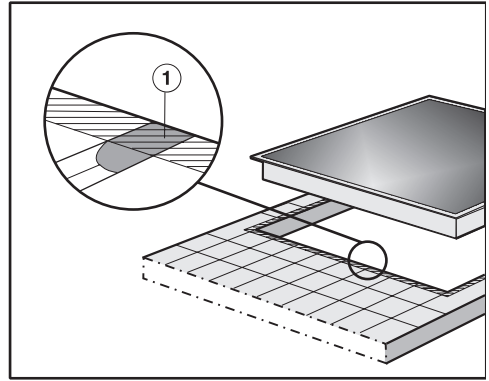

Grout lines ① and the hatched area underneath the appliance frame must be smooth and even. If they are not, the appliance will not sit flush with the worktop and the sealing strip underneath the appliance will not provide a good seal between the appliance and the worktop.

Electrical connection

All electrical work should be carried out by a suitably qualified and competent person in strict accordance with national and local safety regulations.

If the connection cable is damaged, it must be replaced by a suitably qualified electrician with a special connection cable of type H 05 V V-F (pvc insulated), available from Miele.

For extra safety, it is advisable to install a residual current device (RCD), with a trip current of 30 mA.

Connection for each appliance should be made via a suitable isolator.

Note: Isolation of the appliance is required when the appliance safety device is activated. Ensure the isolating switch is easily accessible and visible.

The data plate gives the necessary data for connection.

**WARNING
THIS APPLIANCE MUST BE
EARTHED**

Important

The wires in the mains lead are coloured in accordance with the following code:

Green/yellow = earth

Blue = neutral

Brown = live

As the colours of the wires in the mains lead of this appliance may not correspond with the coloured markings identifying the terminals in your plug, proceed as follows:

- The wire which is coloured green and yellow must be connected to the terminal in the plug which is marked with the letter E or by the earth symbol  or coloured green or green and yellow.
- The wire which is coloured blue must be connected to the terminal which is marked with the letter N or coloured black.
- The wire which is coloured brown must be connected to the terminal which is marked with the letter A or coloured red.

After sales service, data plate, warranty

In the event of any faults which you cannot remedy yourself, please contact Miele.

The contact details for Miele are given at the back of these instructions.

When contacting Miele, please quote the model and serial number of your appliance. These can be found on the data plate.

Space in which to stick the extra data plate supplied with the appliance. Ensure that the model number is the same as the one on the back of these instructions.

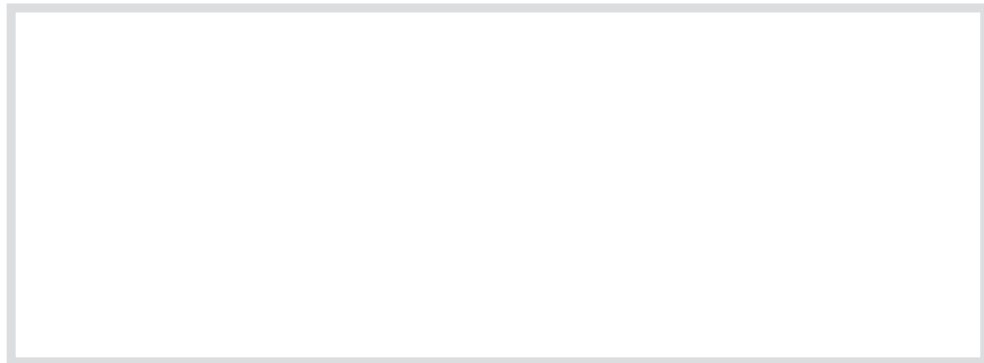

Warranty

The warranty for this appliance is 2 years. For further information, please refer to your warranty booklet.

Miele Australia Pty. Ltd.

ABN 96 005 635 398

Miele Center and Head Office Melbourne:

1 Gilbert Park Drive
Knoxfield, VIC 3180

Miele Center and Office Melbourne:

208-210 Coventry Street
South Melbourne, VIC 3205

Miele Center and Office Sydney:

3 Skyline Place
Frenchs Forest, NSW 2086

Miele Center and Office Brisbane:

39 Harvey Street North
Eagle Farm, QLD 4009

Miele Center and Office Adelaide:

83-85 Sir Donald Bradman Drive
Hilton, SA 5033

Miele Center and Office Perth:

205-207 Stirling Highway
Claremont, WA 6010



www.miele.com.au



**Miele New Zealand Limited
Miele Center and Head Office**

8 College Hill
Freemans Bay
Auckland 1011
New Zealand
Telephone: 0800 264 353
www.miele.co.nz

**Miele Global Headquarters
Germany**

Miele & Cie. KG
Carl-Miele-Straße 29
33332 Gütersloh
Federal Republic of Germany

CS 1312 BG / CS 1322 BG



en - AU, NZ

M.-Nr. 07 233 730 / 12